

Castor wheel bolt for Panthera X

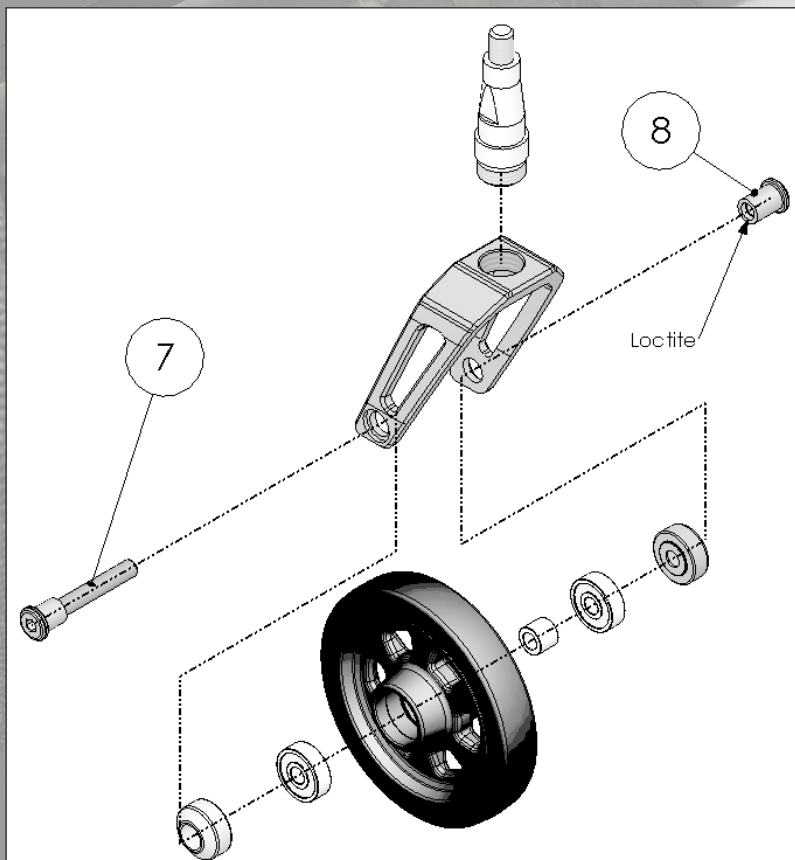

On the first 100 Panthera X delivered, an improper threadlocking (Loctite) has been used on the castor wheel bolt. (pos. 6 och 7)

It has been too strong which mean that the bolt could deform when disassembling the castor wheel, due to the force needed to loosen the bolt.

For those customers that has been affected by this. we offer a new bolt and nut for free. Contact Panthera and we post it without delay.

Pos.	Description	art.no.
6	Bolt fork X	4810132
7	Nut fork X	4810133